



Le fauteuil **FDC1** est une pièce rare et unique. Dessiné dans les années 50 par l'artiste Flavio de Carvalho, ce fauteuil très graphique, presque tribal, est reconnu aujourd'hui comme l'un des plus beaux héritages de cet artiste que Le Corbusier qualifiait de « révolutionnaire romantique ».

The FDC1 armchair is an exclusive and rare piece of furniture designed by artist Flavio de Carvalho in the 50s. This sculptural tribal lounge chair is one of designer's masterpieces, deemed by Le Corbusier as a "romantic revolutionary".

Barre acier carbone ø 14 mm
Cuir

Carbon steel - solid bar ø 0.55"
Leather

Finitions : se référer au tarif
Finishings : refer to price list

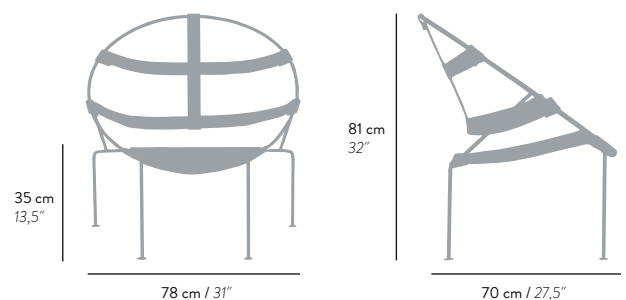



M3.1 - BLACK

acier carbone peinture epoxy
powder coated carbon steel

MÉTAL / METAL



C2.1 - BLACK

Cuir pleine fleur aniline tannage végétal
Full grain aniline vegetable tanned leather



C2.2 - AUBRAC

Cuir pleine fleur aniline tannage végétal
Full grain aniline vegetable tanned leather



C2.3 - LONDON

Cuir pleine fleur aniline tannage végétal
Full grain aniline vegetable tanned leather

CUIR / LEATHER

The high quality steels used by Objekto are produced by very carefully selected French or Italian steel manufacturers.

Stainless steel

Stainless steel is highly resistant to corrosion, but like other steel types, it is not immune from the effects of oxidation under extreme conditions. Stainless steel must be kept clean and free from contaminants to achieve maximum corrosion resistance and aesthetic appeal.

Care

- Clean by using a soft cloth
- Never use cleaning abrasives, steel wool or polish
- Do not use chlorine based liquids on the steel as this will cause the steel to rust
- Keep the material dry

Phosphated carbon steel

Carbon steel is the original raw material used in 1957 for manufacturing the first Paulistano armchair. The carbon steel frame is phosphated. The phosphating process is a surface treatment done in order to stop the first main oxidation. Nevertheless, this frame will oxidize slowly with time, according to modernist precepts.

Care

- Clean by using a soft cloth
 - Never use cleaning abrasives, steel wool or polish
 - Do not use chlorine based liquids on the steel as this will cause the steel to rust
 - Keep the material dry
 - To avoid natural oxidation, clean the steel using a soft cloth impregnated with a special oil for steel (we recommend using WD40™ oil)
- Once done, polish up by using a dry and clean cloth

Powder coated steel

Care

- Clean by using a soft cloth
- Never use cleaning abrasives, steel wool or polish
- Do not use chlorine based liquids

Our leather is vegetable tanned, semi-aniline or aniline. Its raw and natural surface allows the leather to breathe and offers excellent sitting comfort. The leather is full grain, which means that its natural surface structure has been preserved and all natural markings are visible. Natural markings are the hallmarks of the animal's active life and give the piece of furniture a unique sense of character.

Care

- Do not expose to direct sunlight
- Clean by using a soft cloth
- Do not use detergents, chemicals or fats

The canvas used to manufacture our covers are 100% cotton. It is rotproof, waterproof and stainproof for both indoor and outdoor use.

Care

- Clean with a soft brush to remove dust
- Before washing the cover refer to the instructions on the label sewed inside it

Woods originate from European sustainable forests.

Care

- Clean with a soft cloth to remove dust